

REF. NO.	PART NO.	PART NAME	QTY.
1.	E20-9010	MAIN ROTOR BLADE.....	2
2.	E20-3000	(REF.) RETENTION STRAP ASSEMBLY.....	2
3.	E00-2523	BOLT AN5-32A (5/16 X 3-1/4).....	10
	E00-3500	NUT 5/16-24 FIBRLOCK AN365-524A.....	10
	E00-4501	WASHER 5/16 REGULAR AN960-516.....	20
4.	E00-2522	BOLT AN5-30A (5/16 X 3).....	4
	E00-3500	NUT 5/16-24 FIBRLOCK AN365-524A.....	4
	E00-4501	WASHER 5/16 REGULAR AN960-516.....	8
5.	E20-3141	WOOD END PLUG (MAKES 2).....	2
6.	E00-4900	SCREW #4 X 1/2 WOOD.....	20
	E00-4901	SCREW #4 X 3/4 WOOD.....	8
7.	E20-3151	WOOD END PLUG (MAKES 2).....	2
8.	E20-3170	TIP WEIGHT (MAKES 2).....	2
9.	E00-2404	SCREW 1/4-28 7/8" CSK.....	4
	E00-3410	NUT 1/4 THIN LOCK ALL METAL.....	4
10.	E20-7101	(REF.) DOUBLER FIBERGLASS, UPPER.....	2
11.	E20-3131	(REF.) WOOD FILLER BLOCK, UPPER.....	2
12.	E20-7111	(REF.) DOUBLER FIBERGLASS, LOWER.....	2
13.	E20-3121	(REF.) WOOD FILLER BLOCK, LOWER.....	2

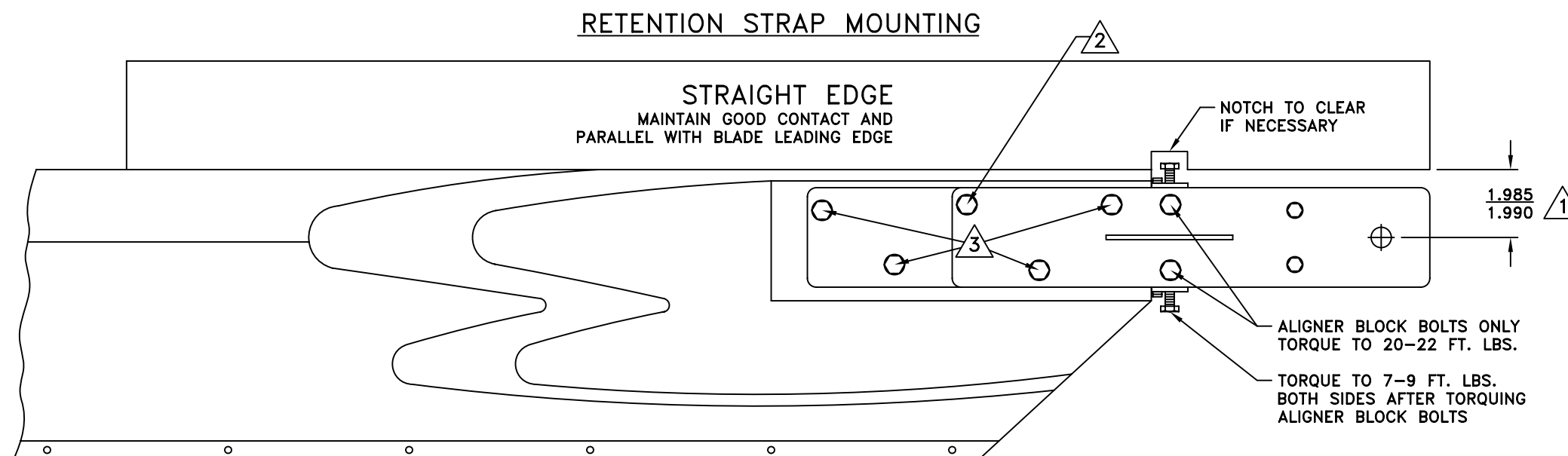
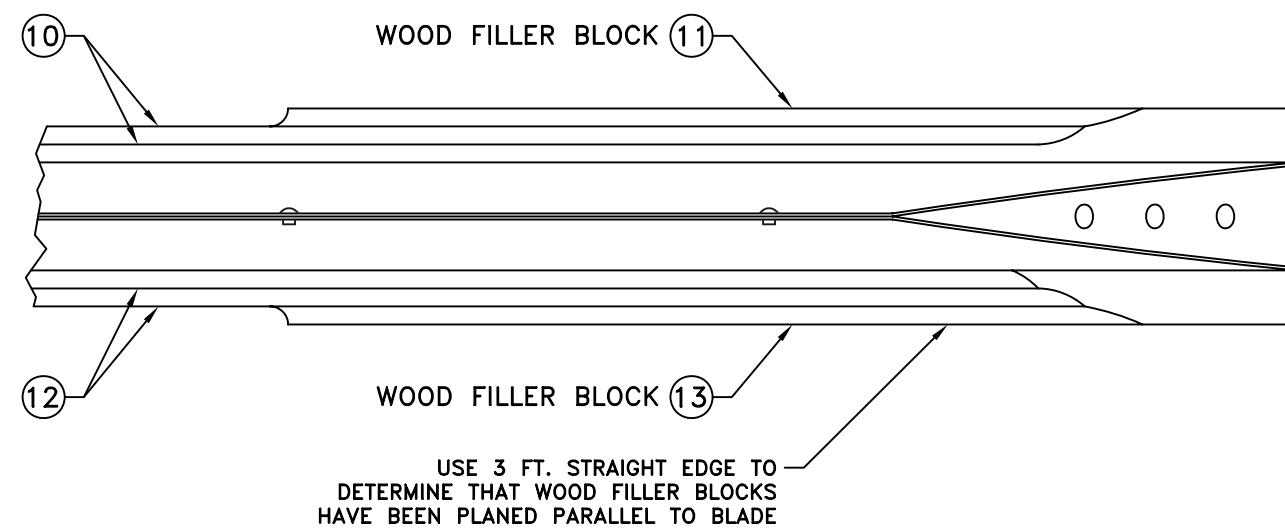

- NOTES:
- 1 WHEN MAKING THIS MEASUREMENT, ALL ITEMS MUST BE LEVEL: BLADE, STRAIGHT EDGE, DIAL CALIPER.
  - 2 PIVOT STRAPS ON THIS BOLT TO GET 1.985-1.990 DIMENSION.
  - 3 AFTER FINDING LOCATION, PASS 5/16 REAMER OR DRILL THROUGH REMAINING HOLES TO ENSURE EASY BOLT FIT.
  - 4 USE A THIN COAT OF 3M STRUCTURAL ADHESIVE BETWEEN STRAP AND WOOD FILLER BLOCK.

ROTORWAY INTERNATIONAL CHANDLER, ARIZONA		
SCALE: NONE	APPROVED BY:	DRAWN BY: WAR
DATE: 1-24-08		REVISED:
<b>MAIN ROTOR BLADES</b>		
MODEL: A600 TALON	DRAWING NUMBER: E20-2000	